

<b>Description</b>	Cartridge pressure regulator suitable for assembly block.		
<b>Media</b>	compressed air or non-corrosive gases		
<b>Supply pressure</b>	max. 12 bar		
<b>Adjustment</b>	Select the pressure regulator according to the desired outlet pressure. The outlet pressure cannot be subsequently adjusted. This safeguards against tampering.		
<b>Relieving function</b>	non-relieving		
<b>Temperature range</b>	-20 °C to 60 °C / -4 °F to 140 °F		
<b>Material</b>	Body: brass Elastomer: NBR	Piston: brass Filter: stainless steel	

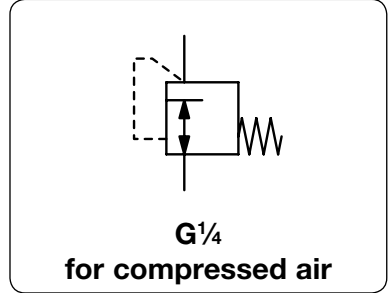

Dimensions		Flow rate l/min*1	Supply pressure max. bar	Connection thread G	Outlet pressure bar*2	Order number
A mm	A/F mm					

Factory-set outlet pressure					P <sub>1</sub> : max. 12 bar, non-relieving, outlet pressure accuracy *2	233
24	14	350	12	G <sup>1</sup> / <sub>4</sub> a	2	233G0220
					3	233G0230
					4	233G0240
					6	233G0260



233

## Special options, add the appropriate letter

<b>NPT</b>	connection thread	233GX2.0
------------	-------------------	----------

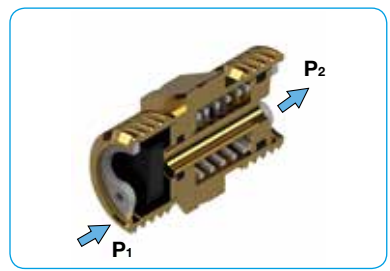

cross section

## Accessories, enclosed

<b>Adapter G<sup>1</sup>/<sub>4</sub></b>	263F0221
---	----------



233 incl. adapter

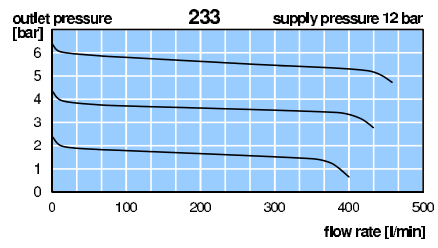
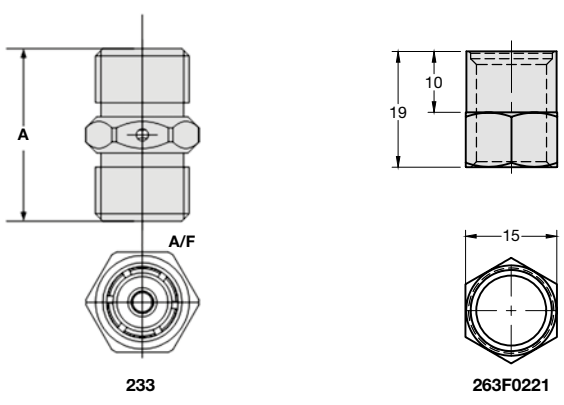

\*1 P<sub>0</sub> = 12 bar; Δp = 0.5 bar  
 \*2 Tolerance: 2 bar ± 0,6 bar (air, P<sub>0</sub> = 6 bar, 10 NI/min)  
 4 bar ± 0,8 bar (air, P<sub>0</sub> = 6 bar, 10 NI/min)  
 6 bar ± 1,0 bar (air, P<sub>0</sub> = 10 bar, 10 NI/min)